

# ALUMINUM PROCESS HEATING



Products and Expertise

## Melting

- TriOx Burners
  - Provides low NOx with best available fuel savings
- HM Burners
  - Improved BTU/# Melt efficiency using cold or preheated combustion air
- RKG Burners
  - Roof firing of dry hearth

## Holding

- SVG/SVC and EJC Burners
  - High velocity holding efficiency
- WHG Burners
  - Stable at low excess air
- WHI Burners
  - Flat flame AND low NOx

## Solution Heat Treating

- NEW Jet Air Gas (JAG) Burner
  - Flame protection tube with furnace atmosphere recirculation
- RTG Burners
  - Radiant tube burners with Radimax plug-in recuperators for indirect firing

## WHI

- Ultra low NOx emissions of 20 ppm or less
- Flat flame profile through entire firing range
- Designed for low excess air operation (5%)
- Cold or preheated air up to 900°F (480°C)
- Available in round or square tile versions

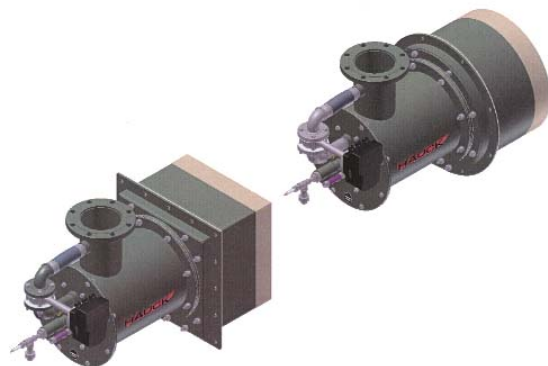

## Jet Air Gas (JAG)

- Low NOx
- No CO
- High efficiency
- All alloy construction
- High on-ratio turndown
- Operate with on/off pulse
- Ideal for direct fired homogenizing furnaces

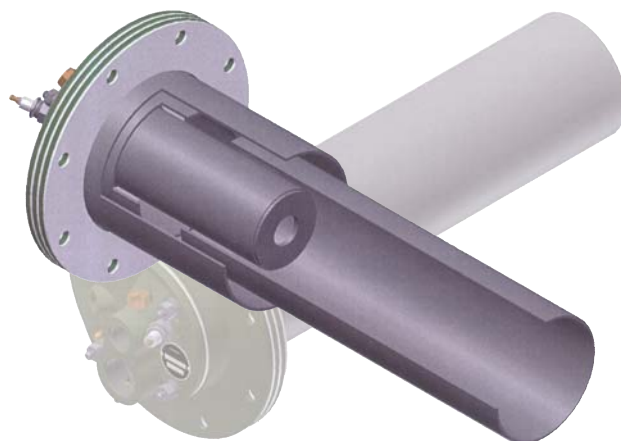

## RTG Burners



- Preheated air operation to 700°F (370°C)
- Flame length control
- Air/Fuel premix adjustment
- Uniform tube heating
- Pair with Hauck's Radimax recuperator for maximum fuel efficiency.

## Radimax Recuperators



- Finned, cast stainless steel recuperator assembly for maximum heat transfer
- Multiple independent orientation of preheated air and exhaust gas outlets
- Increased efficiency and fuel savings
- Low air and exhaust pressure drop
- Preheated air temperatures up to 950°F (510°C)

**HAUCK MANUFACTURING  
COMPANY**

P.O. Box 90  
Lebanon, PA 17042  
Phone: 717-272-3051  
Fax: 717-273-9882  
www.hauckburner.com

# ALUMINUM PROCESS HEATING

PRODUCTS AND EXPERTISE

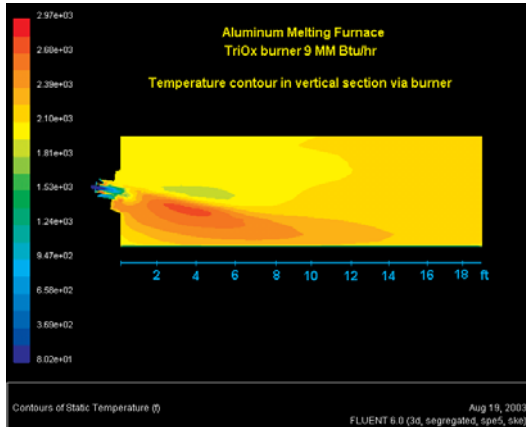

## COMPUTATIONAL FLUID DYNAMICS (CFD)

Using CFD analysis software from FLUENT, Inc., Hauck has successfully combined modeling and experimentation to optimize the design of new and existing burners for industrial heating applications, providing clear insight into fundamental process fluid dynamics, heat transfer, and combustion processes. Predictions from FLUENT® not only provide the designer with powerful visualization capabilities, but also reduce experimentation efforts and product development times. Hauck is also currently using CFD analysis to examine customer applications for improvements in temperature uniformity, performance optimization, efficient burner placement and emissions reduction. Contact Hauck to see how our CFD design and modeling capabilities can be used to solve your industrial heating application issues.

## e-SOLUTIONS FOR COMBUSTION®

*e-Solutions* is a collection of 25 programs designed to be used by combustion engineers responsible for designing, maintaining, and enhancing furnace systems. The programs include reference data, applications data for combustion processes, and a complete system design program. In addition, the program provides:

- Complete Access to Hauck's Online Product Catalog®
- Glossary of Combustion Terminology
- Calculations in US or SI Units
- Help Functions in Each Program

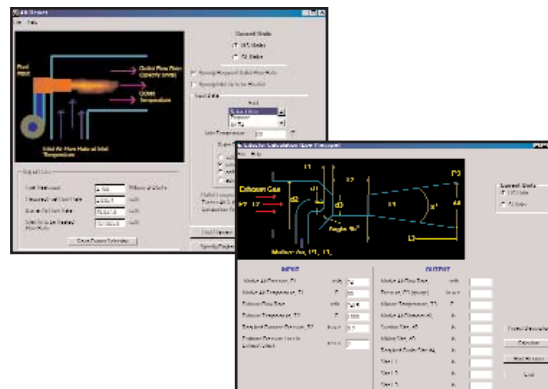

## COMBUSTION TRAINING SCHOOLS

Hauck has updated its combustion training to create the most flexible seminar customizable to suit your training requirements. Conducted over a three-day period, this training allows students to select the sessions which offer the level of training that meets their individual needs. From basic combustion science to advanced computer-driven modeling of combustion applications, this seminar offers the information you need to make the most efficient use of your combustion equipment.

- Day 1 - Basic Combustion Principles
- Day 2 - Advanced Combustion Principles
- Day 3 - e-Solutions for Combustion®

